



**MANUAL DE MONTAGEM
ASSEMBLY INSTRUCTIONS
INSTRUCCIONES DE MONTAJE**

COD BR: BST 21

Sumário Summary Resumen

Introdução Introduction Introducción	3
Antes de começar Before starting Antes de comenzar	4
Evite acidentes Avoid accidents Evitar accidentes	4
Dimensões e ferramentas Dimensions and tools Dimensiones y herramientas	5
Identificação das peças Identifying parts Identificación de las piezas	6
Acessórios incluídos na caixa Hardware included in box Accesorios incluidos en la caja	7
Montagem do móvel Furniture assembly Montaje del mueble	8

Introdução Introduction Introducción

Leia atentamente este manual e siga os passos indicados para que o produto não perca a garantia e também para uma perfeita montagem.

Read this manual and follow the steps in order to keep the guarantee and also for the perfect fit.

Lea este manual y siga los pasos para que el producto no pierda la garantía y también para el ajuste perfecto.

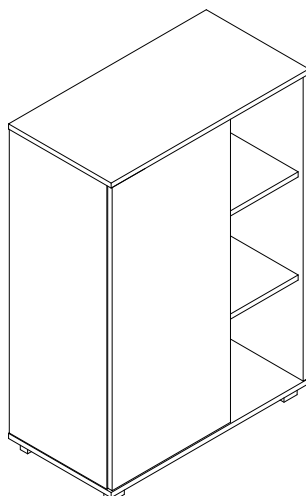

Antes de começar Before starting Antes de comenzar

Antes de começar a montagem prepare o ambiente, deixando-o completamente limpo e com bom espaço para iniciar o trabalho.

Prepare the room before starting the assembly, leaving it completely clean and the area in good condition to start the work.

Antes de comenzar el montaje preparar el ambiente, dejándolo completamente limpio y con bueno espacio para comenzar el trabajo.

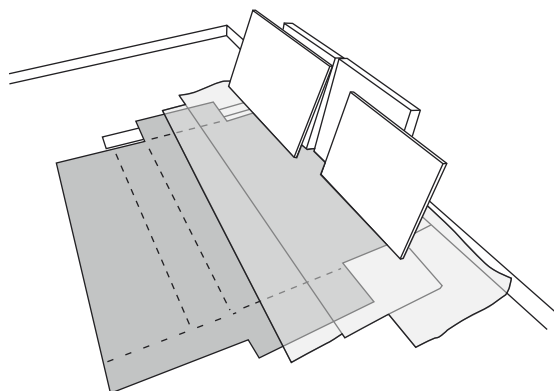

Utilize o papelão da própria embalagem para separar e apoiar as peças retiradas das caixas.

Use the cardboard of the packaging to separate and support the parts removed from the boxes.

Utilice el cartón de la embalaje para separar y apoyar las piezas desmontadas de las cajas.



Forre a área de montagem com um cobertor ou tapete. Assim, você evita avarias nas peças durante o processo de montagem.

Cover the assembly area with a blanket or carpet to avoid damaging the parts during the assembly process.

Cubrir la zona de ensamble con una manta o alfombra. De este modo, se evitan daños en las piezas durante el proceso de montaje.



Evite acidentes Avoid accidents Prevenir accidentes

Solicitamos observar atentamente as orientações de montagem como: fixação do produto na parede, colocação de cola em locais específicos necessários, o peso suportado pelo produto, etc...

We request you to carefully observe the assembly instructions as: fixing the product on the wall, adding glue in needed and specific places, product weight limit, etc.

Pedimos que lea atentamente las instrucciones, principalmente las informaciones de fijación del producto en la pared, colocación de pegamento en local específico y necesario, el peso soportado por el producto etc...

Não escale ou se apoie no móvel.

Do not climb or lean on the furniture.

No se suba ni se apoye en el mueble.

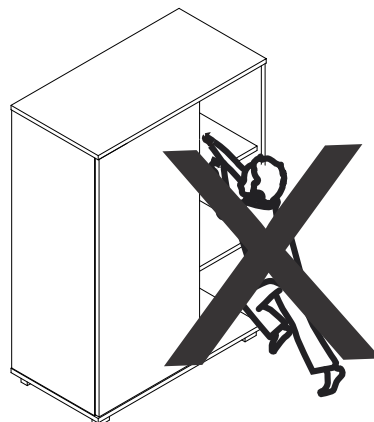

Dimensões e ferramentas
Dimensions and tools
Dimensiones y herramientas

Dimensões:

L: 675 A:965 P: 350 mm

Dimensions:

W: 26.57 H: 37.99 D: 13.77 inches

Dimensiones:

L: 675 A: 965 P: 350 mm

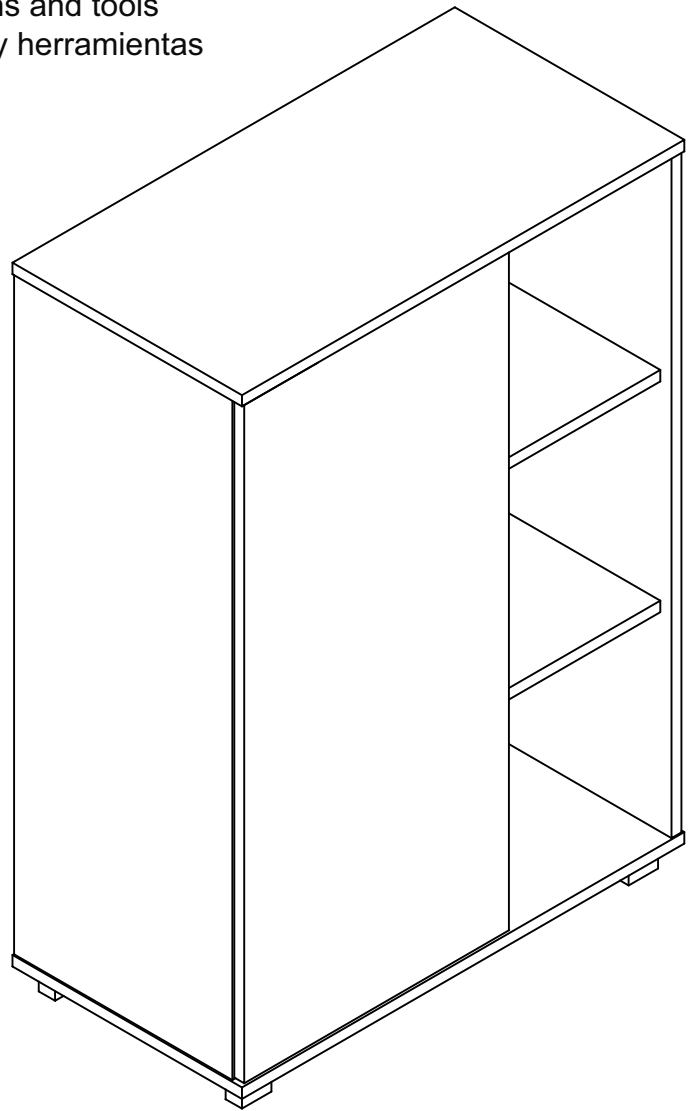

Limpeza
Cleanig
Limpieza

Pano levemente umedecido com água, seguido de pano seco, não utilizar produtos químico ou abrasivos.
Slightly dampened cloth and after a dry cloth, do not use chemicals or abrasives.
Solamente utilizar un paño húmedo y después un paño seco, no utilice productos químicos o abrasivos.

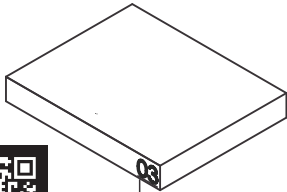

UTILIZE ALCOOL APENAS PARA REMOVER O NUMERO DAS PEÇAS
USE ALCOHOL ONLY TO REMOVE PART NUMBERS
UTILICE ALCOHOL SOLAMENTE PARA ELIMINAR EL NUMERO DE LAS PIEZAS

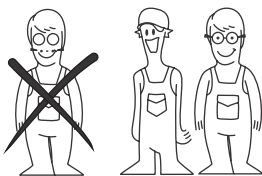

Para facilitar a montagem, utilize uma parafusadeira elétrica.
To improve assembly, use an eletronic screwdriver.
Para facilitar el armado, utilice un destornillador eléctrico.

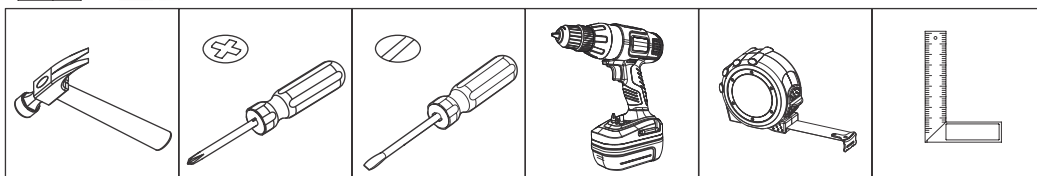

COD BR: BST 21

PEÇA	DESCRIÇÃO	QUANT.	PART	DESCRIPTION	QTY	PIEZA	DESCRIPCIÓN	CANTIDAD
001	BASE	1	001	BASE	1	001	BASE	1
002	TAMPO	1	002	TOP	1	002	TAPA	1
003	LATERAL ESQUERDA	1	003	LEFT SIDE	1	003	LATERAL IZQUIERDA	1
004	LATERAL DIREITA	1	004	RIGHT SIDE	1	004	LATERAL DERECHA	1
005	DIVISÓRIA	1	005	PARTITION	1	005	PARTICIÓN	1
006	PRATELEIRA	2	006	SHELF	2	006	REPISA	2
007	PORTA	1	007	DOOR	1	007	PUERTA	1
008	COSTA MAIOR	1	008	LONGER BACK	1	008	REVÉS MAYOR	1
009	COSTA MENOR	1	009	LOWER BACK	1	009	REVÉS MENOR	1
010	ARAME	6	010	WIRE	6	010	CABLE	6

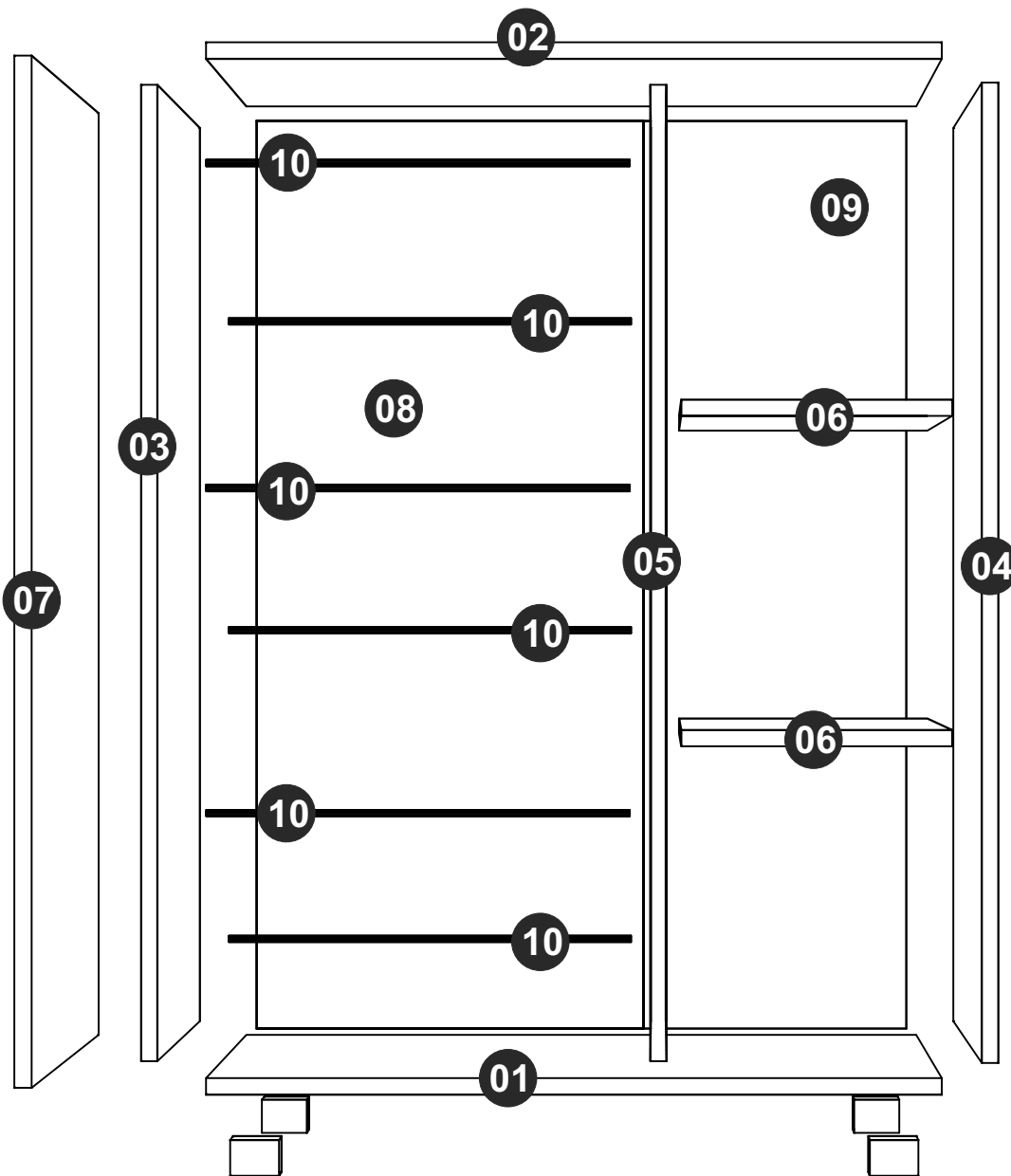



EF 000033 x 20
8X30



EF 000094 x 14



EF 000216 X 14



EF 000106 x 08
3,5X14 CC



EF 000168 X 70
10X10 C/C



EF 000404 x 08
3,5X25 CC



EF 000132 x 06
4X50 CC



GIZ x 01
CHALK x 01
TIZA x 01

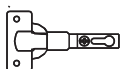

EF 000044 X 02



EF 000024 X 02

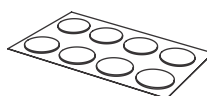

TAPA FUROS x 14
STICKER x 14
TAPAS PLÁSTICAS x 14



PÉS RETÂNGULARES x 04
RETANGULAR FEET x 04
PIES RECTANGULARES x 04

Utilize para medir as ferragens.

Utilice para medir el herraje.

Use for measuring the hardware.

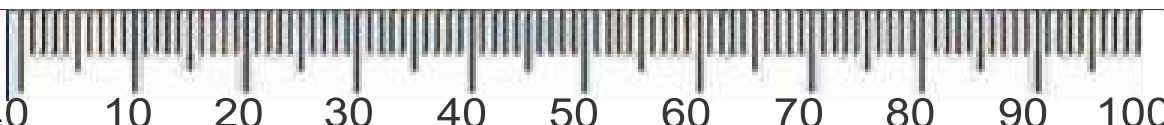

Garantia (exclusivo para o Brasil/exclusivo de Brasil/exclusive to Brazil):

A garantia dos produtos fabricados pela BRV Móveis, abrange eventuais defeitos-vícios de fabricação, no prazo estabelecido pelo código de Defesa do Consumidor, em seu artigo 26.II. o qual prevê a garantia de 90 (noventa) dias.

A = 8KG - 17.63LB

B = 4KG - 8.81LB

C = 2KG - 4.40LB

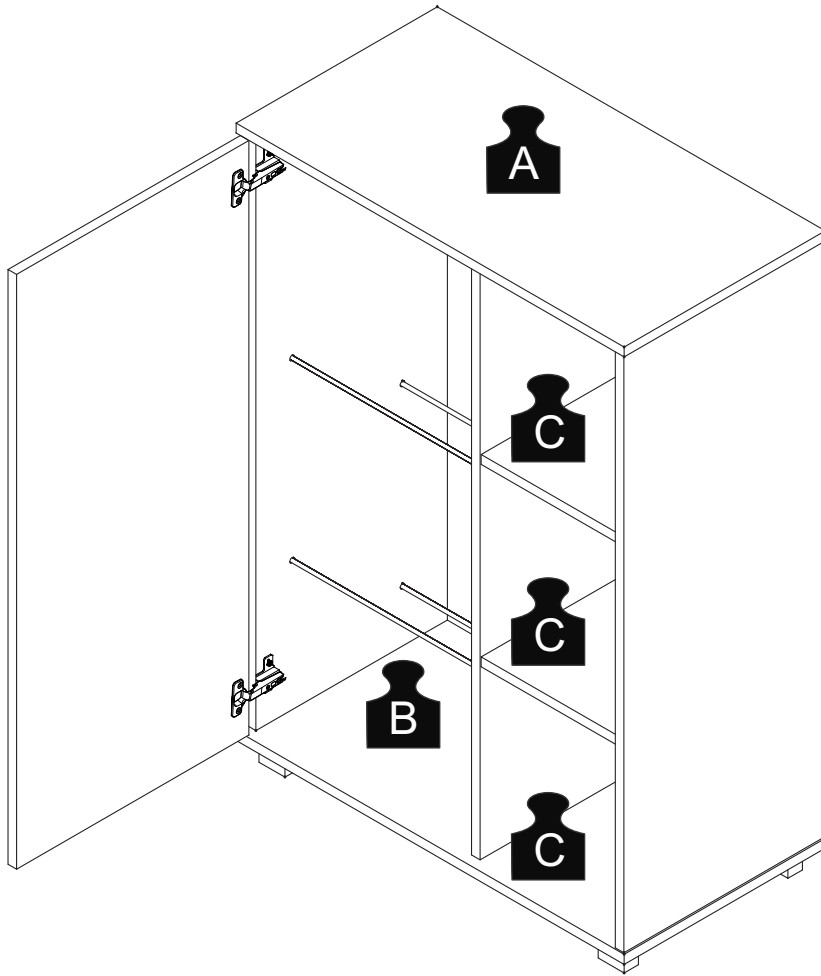

PASSO 1 / STEP 1 / PASO 1

Insira a ferragem EF 000094 nas peças 02, 04 e 05.
Insert hardware EF 000094 into pieces 02, 04 and 05.
Añade el herraje EF 000094 en las piezas 02, 04 y 05.

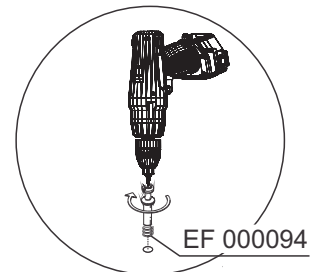
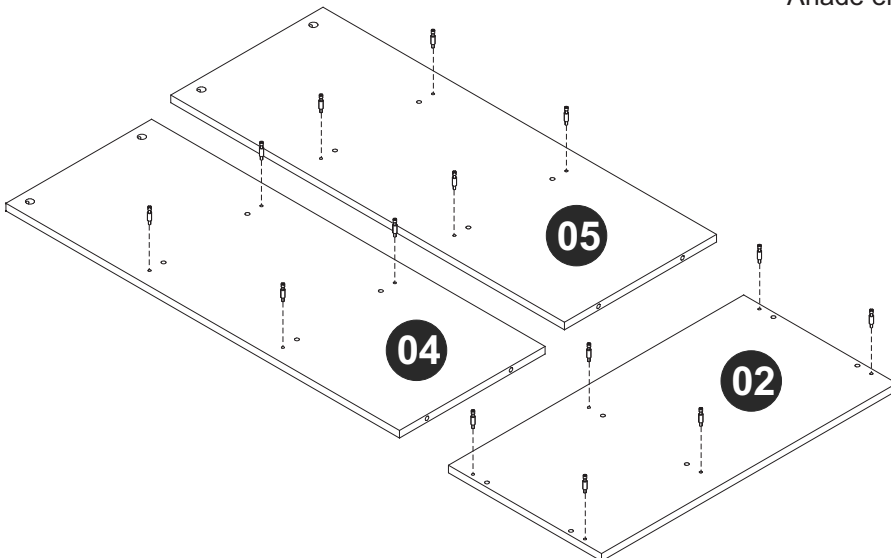

PASSO 2 / STEP 2 / PASO 2

Insira a ferragem EF 000033 nas peças 03 ,04, 05 e 06.
Fixe a ferragem EF 000024 usando a ferragem EF 000106 na peça 03.
Insert hardware EF 000033 into pieces 03 ,04, 05 and 06.
Fix hardware EF 000024 using hardware EF 000106 into piece 03.
Añade el herraje EF 000033 en las piezas 03 ,04, 05 y 06.
Fije el herraje EF 000024 utilizando el herraje EF 000106 en la pieza 03.

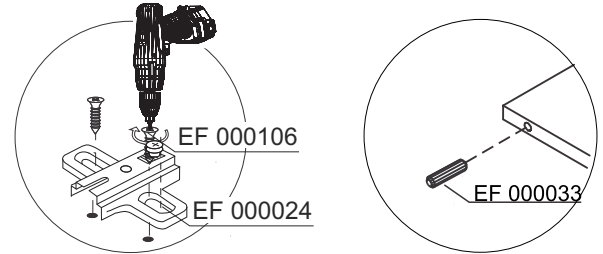
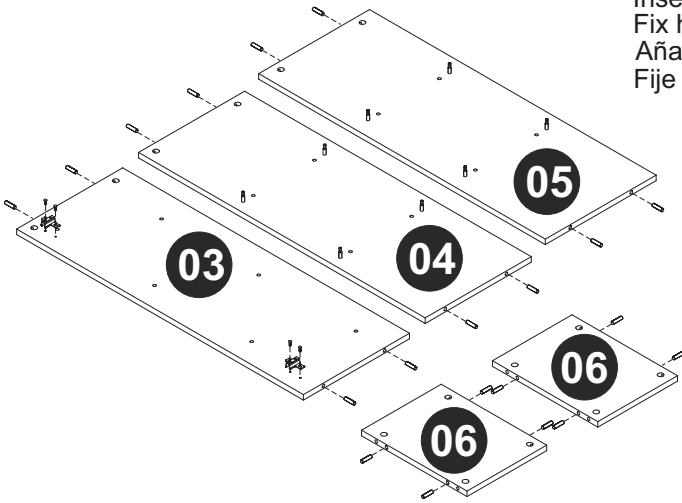

PASSO 3 / STEP 3 / PASO 3

Fixe a ferragem EF 000044 usando a ferragem EF 000106.
Fix the hardware EF 000044 using hardware EF 000106.
Fije el herraje EF 000044 utilizando el herraje EF 000106.

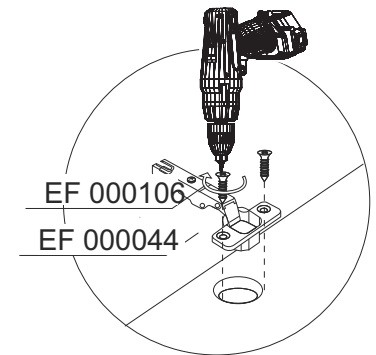
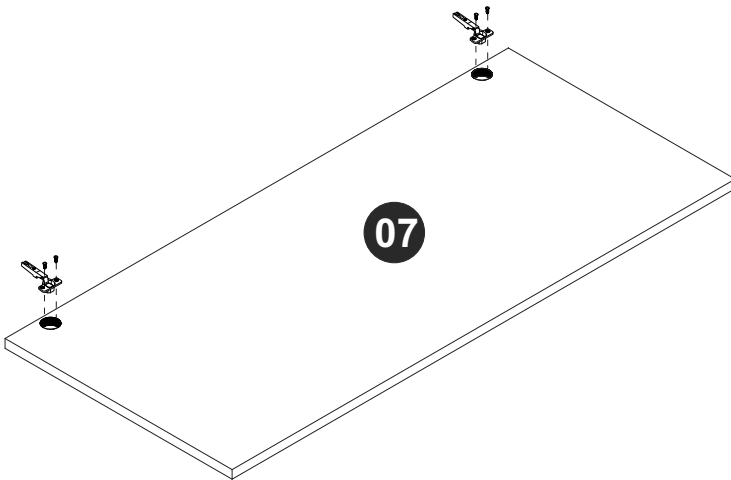

PASSO 4 / STEP 4/ PASO 4

Conecte as peças 04 e 06, insira a ferragem EF 000216 e gire para apertar.
Connect pieces 04 and 06, insert hardware EF 000216 and turn to tighten.
Junte las piezas 04 y 06, añade el herraje EF 000216 y gire para apretar.

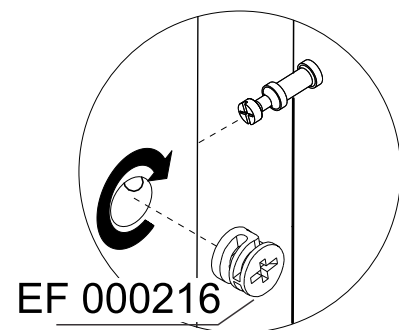
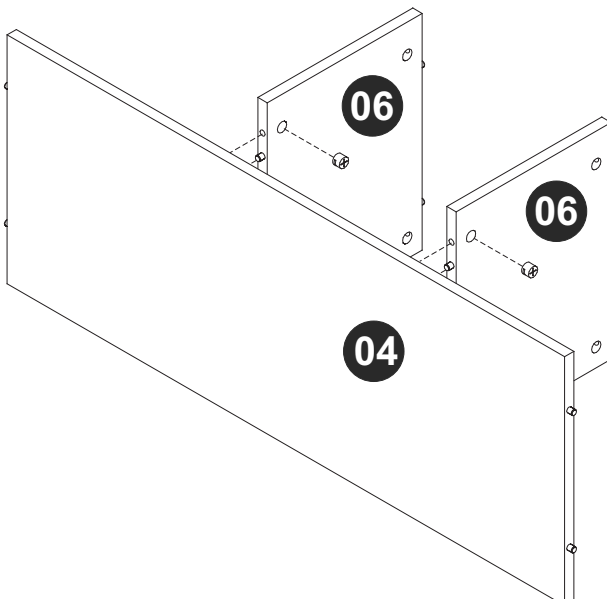

PASSO 5 / STEP 5 / PASO 5

Conecte as peças 05 e 06, insira a ferragem EF 000216 e gire para apertar.
Connect pieces 05 and 06, insert hardware EF 000216 and turn to tighten.
Junte las piezas 05 y 06, añade el herraje EF 000216 y gire para apretar.

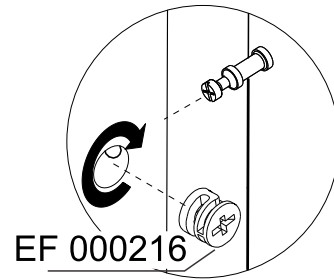
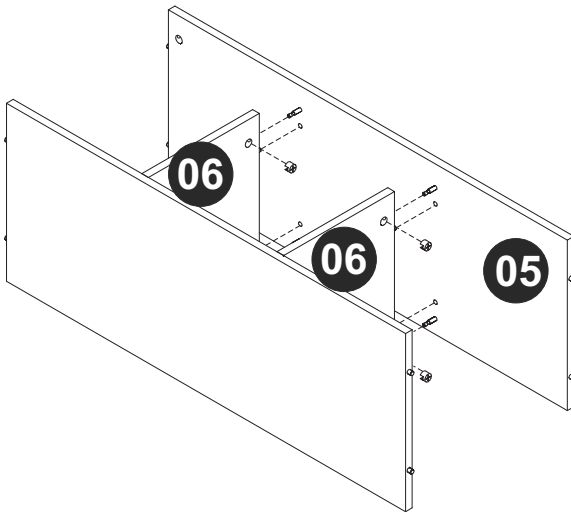

PASSO 6 / STEP 6 / PASO 6

Conecte os arames entre as peças 03 e 05.
Connect the wire between pieces 03 and 05.
Junte el cable entre las piezas 03 y 05.

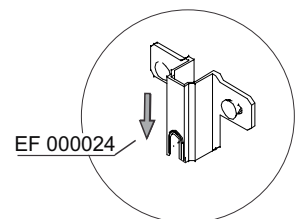
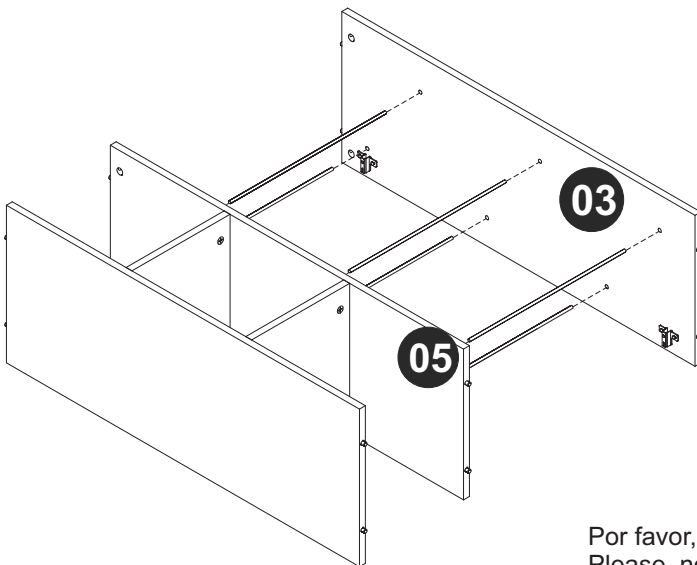

Por favor, observe a posição da ferragem EF 000024
Please, note hardware EF 000024 position.
Por favor, observe la posición del herraje EF000024.

PASSO 7 / STEP 7 / PASO 7

Conecte a peça 02 à parte montada no passo anterior, insira a ferragem EF 000216 e gire para apertar.
Connect piece 02 to the part assembled into the previous step, insert hardware EF 000216 and turn to tighten.
Junte la pieza 02 a la parte armada en el paso anterior, añade el herraje EF 000216 y gire para apretar.

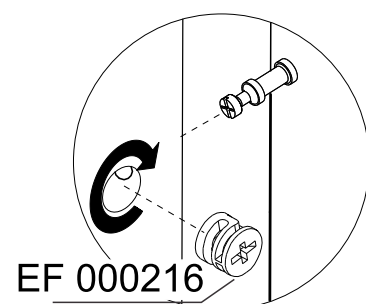
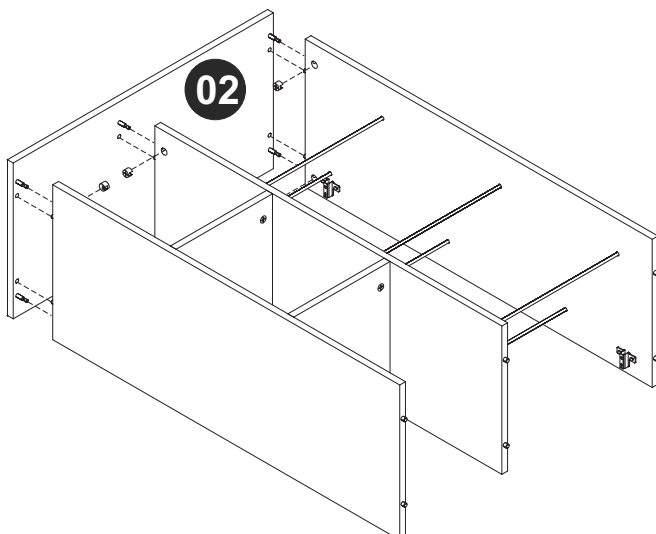

PASSO 8 / STEP 8/ PASO 8

Conecte a peça 01 ao móvel montado utilizando a ferragem EF 000132.
Connect piece 01 at the assembled furniture using hardware EF 000132.
Junte la pieza 01 al mueble armado utilizando el herraje EF 000132.

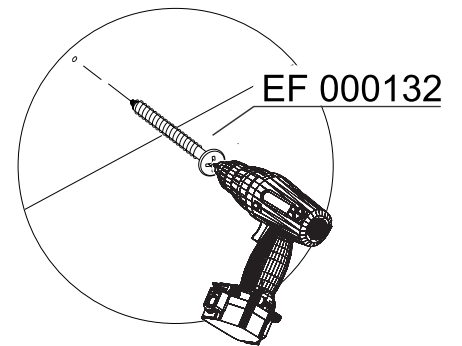
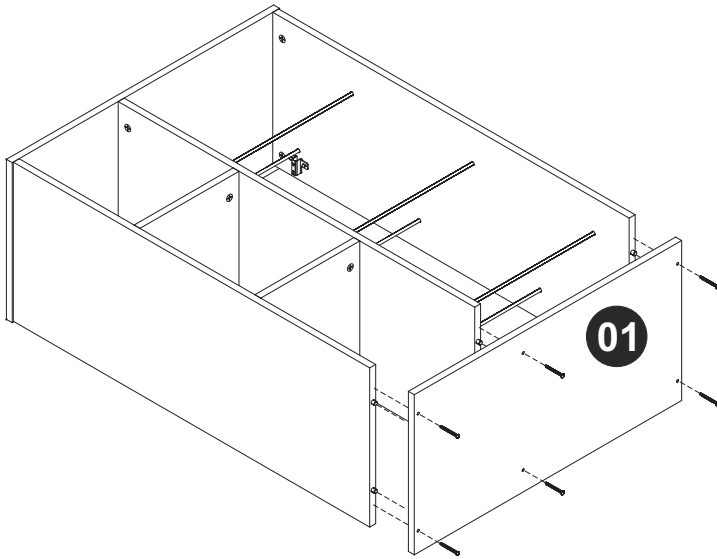

PASSO 9 / STEP 9 / PASO 9

Utilize a ferragem EF 000404 para fixar os pésna peça 01.
Use hardware EF 000404 to attach the feet into piece 01.
Utilice el herraje EF 000404 para fijar los pies en la pieza 01.

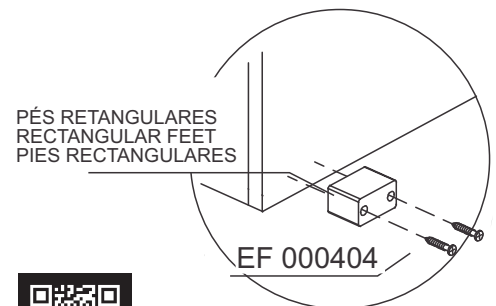
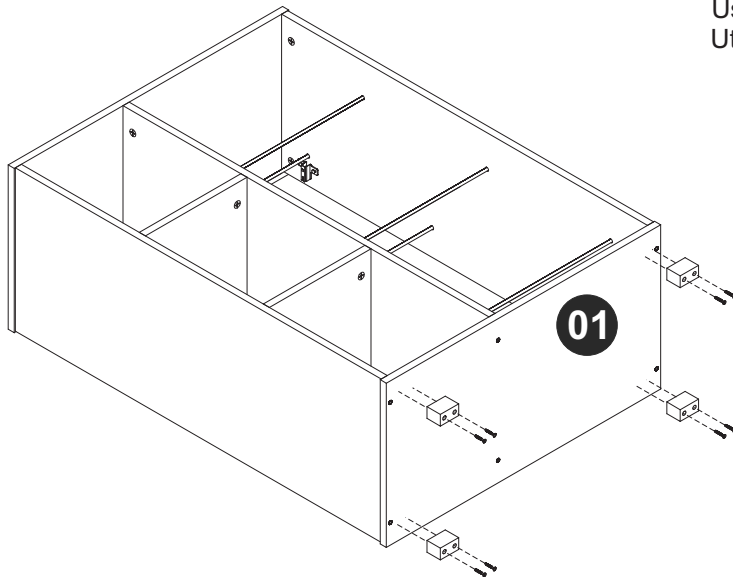

PASSO 10 / STEP 10 / PASO 10

Fixe as peças 08 e 09 ao móvel utilizando a ferragem EF 000168.
Attach pieces 08 and 09 at the furniture using hardware EF 000168.
Fije las piezas 08 y 09 al mueble utilizando el herraje EF 000168.

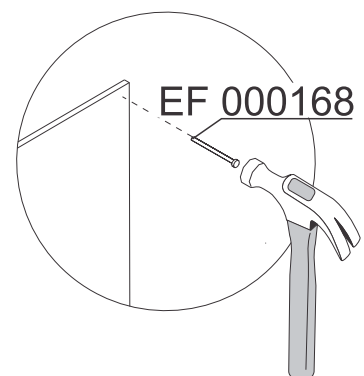
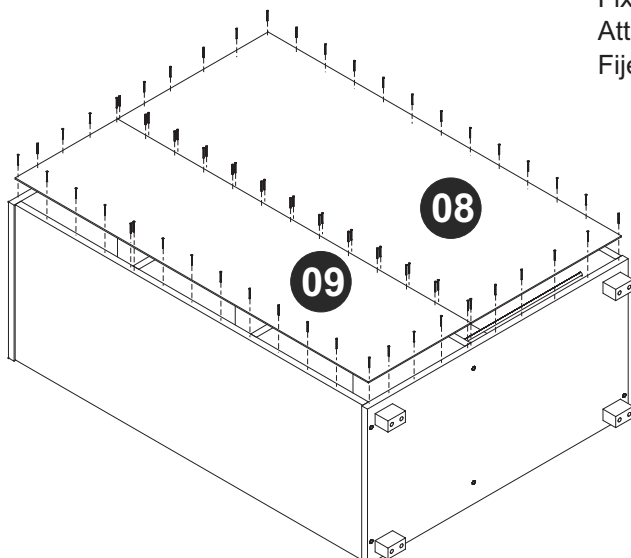

PASSO 11 / STEP 11/ PASO 11

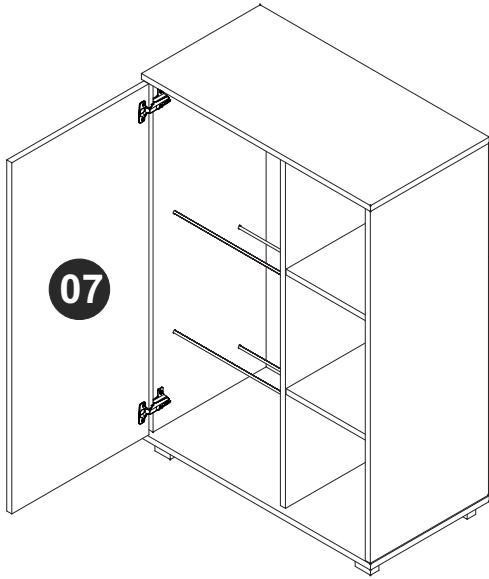

Fixe a peça 07 ao móvel .
Fix piece 07 at the furniture.
Fije la pieza 07 al mueble.

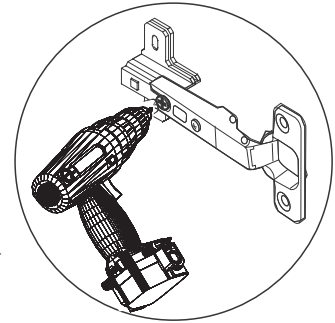

PASSO 12 / STEP 12 / PASO 12

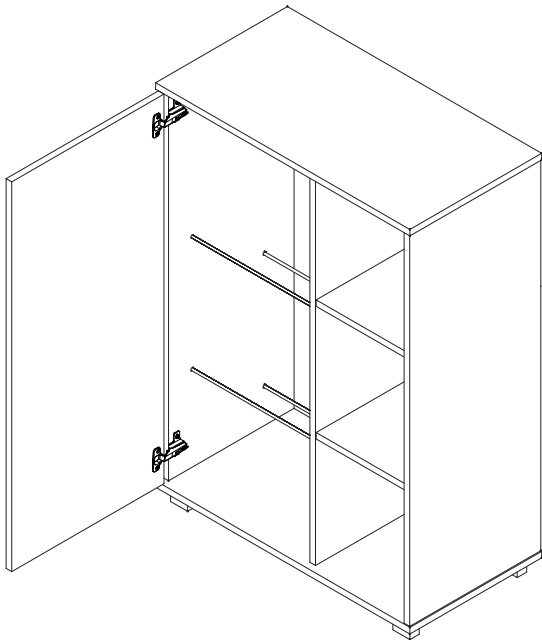

Utilize o tapa furos para cobrir os parafusos aparentes.
Use the sticker to cover the apparent screws.
Utilice los tapa huecos para cubrir los tornillos aparentes.

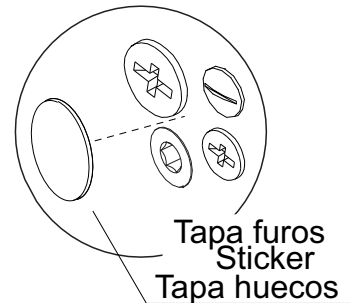

PASSO 13 / STEP 13 / PASO 13

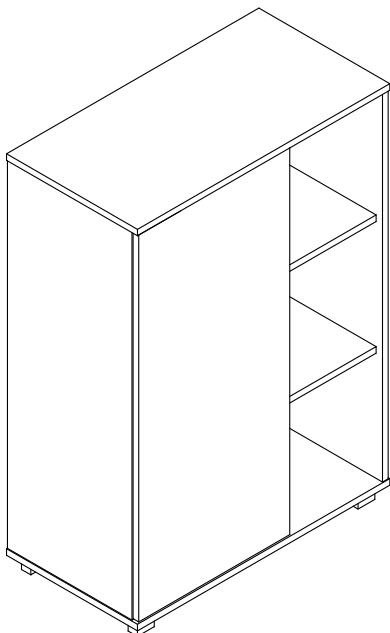

Utilize o giz para dar o acabamento final ao produto.
Use the chalk to give the final finish on the product.
Utilize la tiza para dar el acabado final al producto.

